

The CSM-9 is a compact SMD Crystal. The 8.0 x 4.5 x 1.8 mm ceramic package is ideal for PCMIA ethernet applications.

Request a Sample

OPERATING CONDITIONS / ELECTRICAL CHARACTERISTICS



- Low Profile
- 8.0 x 4.5 mm Footprint
- Extended Temp. Range Option
- RoHS Compliant

PARAMETERS	CONDITIONS	CSM-9			UNITS
		MIN	TYP	MAX	
Frequency		4.000		50.000	MHz
Mode of Oscillation	Fundamental				
Frequency Tolerance*	@ +25°C			± 30	ppm
Frequency Stability*	-20 ~ +70°C			± 30	ppm
Shunt Capacitance	Co			5	pF
Load Capacitance	Specify in P/N	8	20	Series	pF
Drive Level	DL			100	µW
Operating Temperature*	Topr	-10		+70	°C
Storage Temperature	Tstg	-55		+125	°C
Aging (First Year)	@ +25°C ±3°C			±5	ppm

DIMENSIONS (mm)

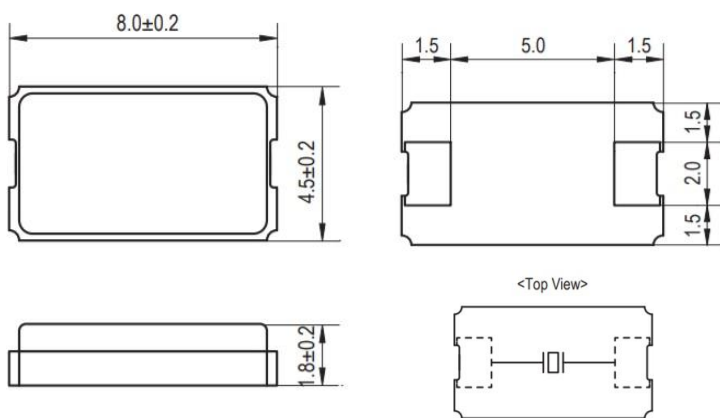

Figure 1) Top, Side, and Bottom

Crystal is symmetrical, pad 1 & 2 are interchangeable.
Chamfer on the bottom pad has no electrical significance.

Frequency (MHz)	ESR Ω Max.
4.000 ~ 7.999	300
8.000 ~ 9.999	200
10.000 ~ 11.999	100
12.000 ~ 12.999	80
13.000 ~ 50.000	50

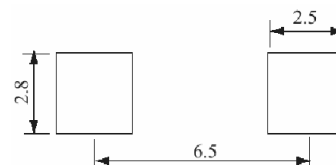

Figure 2) Suggested land pattern

Pad Connections	
1	In/Out
2	Out/In

PART NUMBERING GUIDE: Example ECS-200-20-35-TR

ECS - FREQUENCY ABBREVIATION	LOAD CAPACITANCE	PACKAGE	AVAILABLE OPTIONS	PACKAGING
			Tolerance Stability Temp Range	
ECS	200 = 20.000 MHz See P/N Guide	35 = CSM-9	Blank = Std A = ± 25 ppm D = ± 100 ppm E = ± 50 ppm G = ± 30 ppm H = ± 25 ppm J = ± 20 ppm † K = ± 10 ppm † R = ± 15 ppm T = ± 20 ppm † W = ± 15 ppm † X = ± 10 ppm †	Blank = Std L = -10 ~ +70°C M = -20 ~ +70°C N = -40 ~ +85°C P = -40 ~ +105°C S = -40 ~ +125°C U = -55 ~ +125°C
				TR = Tape & Reel 1K/Reel

* Specify available options in P/N.

† Contact ECS for availability over extended temp range.

Rev.2017

POCKET TAPE DIMENSIONS (mm)

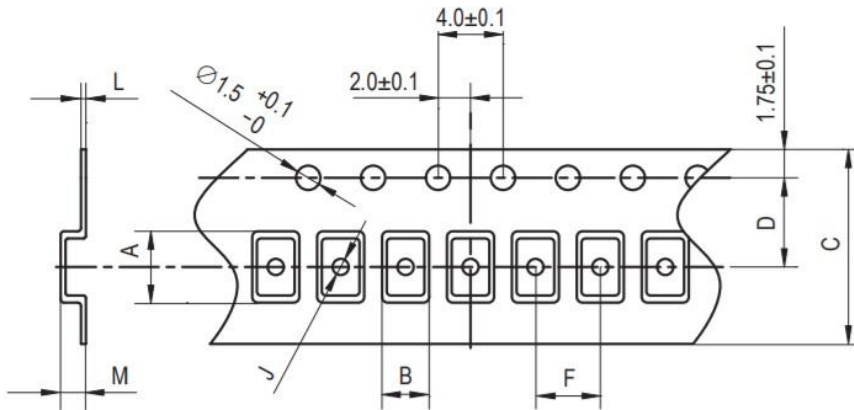

A	B	C	D	F	J	L	M	Reel Dia.	Qty/Reel
8.4	4.8	16.0	7.5	8.0	1.5	0.3	2.0	330	1000pcs

SOLDER PROFILE	
Peak solder Temp +260°C Max 10 sec Max.	
2 Cycles Max.	
MSL 1, Lead Finish Au	

DEVELOPED FREQUENCIES	
Abbreviation	Frequency (MHZ)
040	4.000
049	4.91520
080	8.000
081.92	8.912
110.5	11.0592
143	14.31818
184	18.432
200	20.000
283.22	28.322

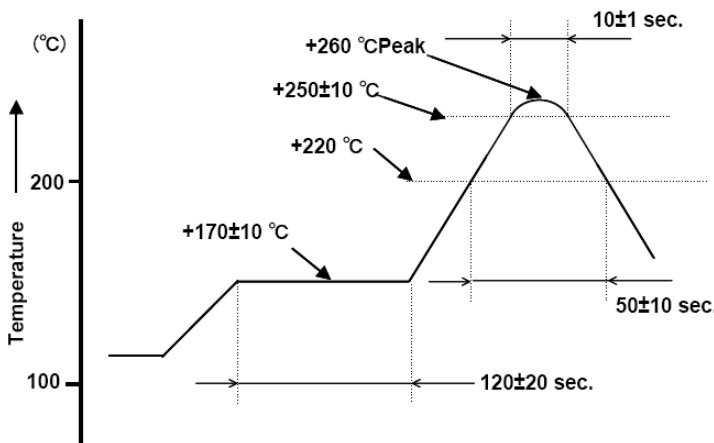

Figure 1) Suggested Reflow Profile